

Revision no: 01 Rev date: 30/01/2009	Technical specification Fast Rescue Boat	
Doc No: FRB750-TS134-00	FRB 750	Page 1 of 4

1. Technical Data

Dimension:

LOA	: 7.50 m
WOA	: 2.32 m
HOA	: 2.30 m

Boat data

Number of persons	: 15
Weight, empty boat	: 1820 kg
Weight, davit load	: 2945 kg
Standard propulsion	: Water jet
Model	: BUKH STEYR 236
Speed	: 30 knots
Towing force	: 4.0 kN
Lifting arrangement	: Single point

2. General Description

Rigid FRB with an inboard diesel engine, equipped with a self righting frame at the stern. The FRB is suitable for carrying up to 15 persons.

The deep V-shaped hull gives a good sea performance, also in high speed. It is designed for both A-frame davits and single arm davits.

The FRB is primarily designed for SAR/MOB operations, secondarily for crew transfer, inspections and so on.

It has good manoeuvrability, it is easy to operate and has a design which makes the maintenance easier.

3. Regulations

The FRB fully complies with the latest SOLAS requirements and LSA Code. The FRB will be certified by Bureau Veritas in accordance with the European Council Directive 96/98 EC on Marine Equipment (M. E. D).

Revision no: 01 Rev date: 30/01/2009	Technical specification Fast Rescue Boat	
Doc No: FRB750-TS134-00	FRB 750	Page 2 of 4

4. Lifting Arrangement

Single point lifting arrangement with approved on/off load release hook, Standard supply NOREQ-HOOK 3T. It is connected through a stainless steel frame to the hull bulkheads.

Optional; HMK 3.5 hook from H. Henriksen.

5. Deck and Hull

The boat is made out of fire retardant glass fibre reinforced polyester material (GRP). Main parts are laminated in independent moulds. To assure buoyancy and strength, foam is injected into certain areas between the inner liner and the hull. To assure hull strength, the hull has two longitude bulkheads and one transverse bulkhead.

A heavy duty fender made out of polyurethane foam is protecting the boat from impacts. The fender is connected to the hull with glue and protected with two layers of PVC cover. The fender also gives extra buoyancy.

The boat is equipped with an anti-skid surface deck.

All steel used are of 316 L quality.

6. Engine and Accessories

FRB 750 is equipped with a BUKH STEYR inboard diesel engine. The engine satisfies the requirements of 1996 amendments to SOLAS 1974 and LSA Code. The engine is also approved by Classification Society.

Revision no: 01 Rev date: 30/01/2009	Technical specification Fast Rescue Boat	
Doc No: FRB750-TS134-00	FRB 750	Page 3 of 4

Technical data:

- Maker : BUKH STEYR
- Model : MO236K43
- Type : Turbocharged, 4 stroke, 6 cylinders
- Power : 212 hp(156 kW)
- Cooling : Fresh water
- Starting method : Electric starting
- Alternator : 90 Amp with voltage regulator
- Starter : 12 V,1.8 hp (1.3 kW)
- Spare parts : One set
- Transmission : Alamarine water jet 230
- Fuel capacity : 160 ltr

Particulars:

- Dead man switch providing emergency engine shut off
- Fuel sufficient for 4 hours operation

7. Fittings and Console

The main operation of the boat is carried out from the helmsman's position behind the console system fitted mid-ship.

The following equipment is fitted on the console:

- Hydraulic steering gear
- Remote control for engine right hand side
- Hand held search light
- Compass
- Switch panel
- Battery switch

8. Electrical equipment

Standard supply is a 42V LADAC battery charger, charging the two independent 12V batteries. The electric system is controlled by a battery switch, together

Revision no: 01 Rev date: 30/01/2009	Technical specification Fast Rescue Boat	
Doc No: FRB750-TS134-00	FRB 750	Page 4 of 4

with a switch panel for navigation lights (red, green and white), compass light and search light.

Electric equipment is according to IP 66 standard.

9. Self righting capability

At the stern a buoyancy foam filled arrangement is mounted. This will make the boat capable of returning to upright position after capsizing. During capsizing the engine will automatically be shut off.

10. Equipment

The equipment required by LSA regulation is provided.

The painter release hook is fitted at the bow, buoyant lifelines and grips are fitted on both sides.

11. Documentation

Following final documents are submitted after delivery:

- Product specifications
- General arrangement drawings
- Manuals
- Instructions for on-board maintenance of lifeboat

12. Guarantee

NOREQ AS' liability for defects is limited to defects which appear within a period of 12 months from the buyer's further delivery of the equipment to the buyer's customer as an integrated part of the ship, or within a maximum of 18 months from delivery to the buyer, whichever comes first.

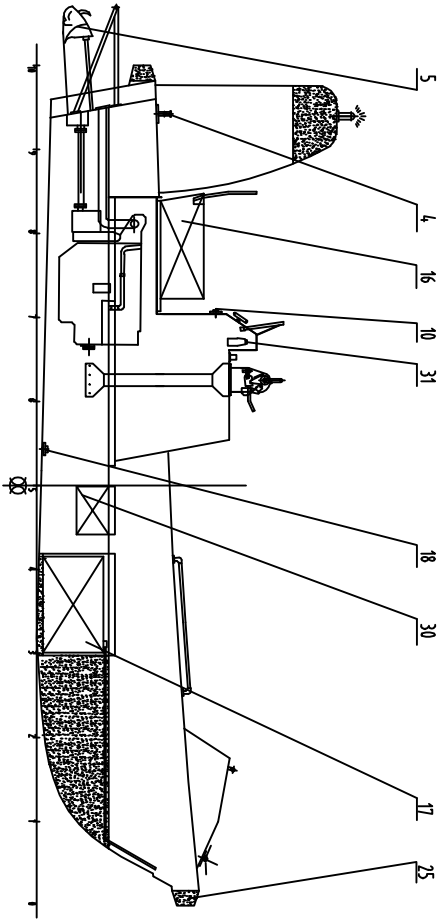
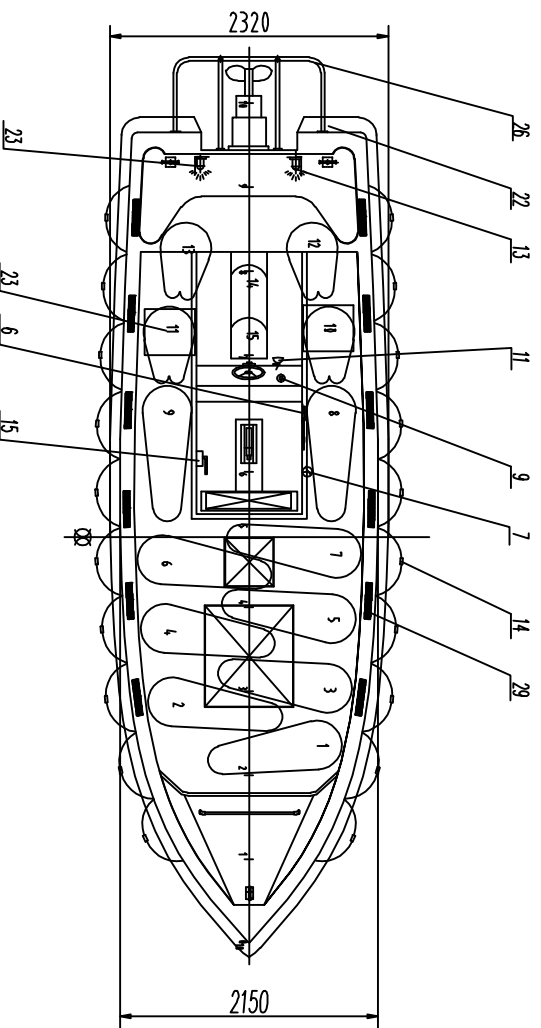
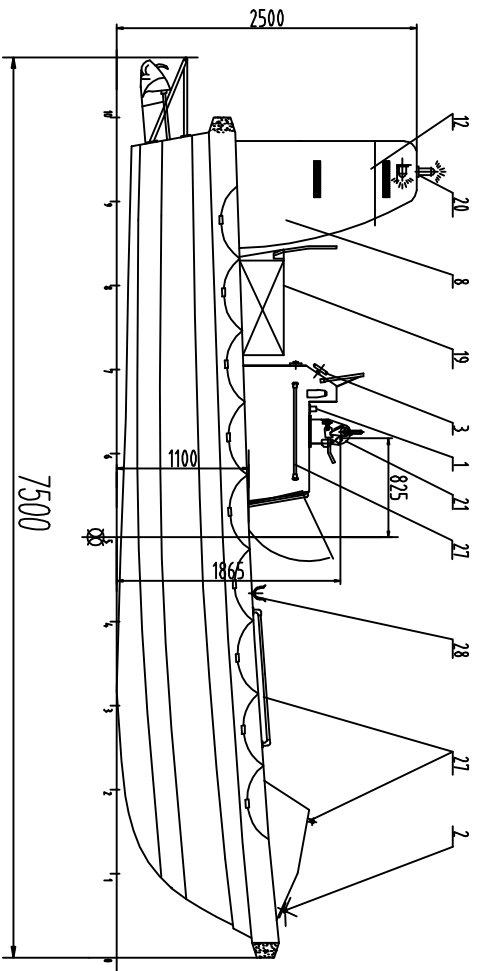

31	Charger socket	1	Product	
30	Storage box	1	F.R.P	
29	Reflector band	24	Plastic	
28	Door crutch	2	Stainless steel	
27	Rail	1	Stainless steel	
26	Protected rail	1	Stainless steel	
25	Fender	1	Foam	
23	Chair	2	F.R.P	
22	Shelter	2	Rubber	
21	Hook device	1	Assemble	
20	Position light	1	Product	
19	Pilot chair	1	F.R.P	
18	Drain plug	1	Brass	
17	Fuel oil tank	1	A3	
16	Battery tank	1	F.R.P	
15	Manual pump	1	Product	
14	Lifeline device	1	Assemble	
13	Port light	1	Product	
12	Starboard light	1	Product	
11	Search light	1	Product	
10	Switch	1	Product	
9	Compass	1	Product	
8	Fuel tank	1	F.R.P	
7	Extinguisher	1	Product	
6	Hatchel	1	Product	
5	Water/air engine	1	Assemble	
4	Bit	2	Stainless Steel	
3	Control device	1	Assemble	
2	Painter device	1	Assemble	
1	Radar reflector seat	1	Stainless steel	
Item	Description	Qty	Material	Remark

Design: Yang Ji Ping
 Check: Peng De Xing
 Approval: Ding Yu Fei
 Date: 04/2007

General Arrangement Plan
 Fast Rescue Boat
 NOREQ-FRB 750

Dwg No. JCS750-01
 Page B-1

