

Revision no: 01 Rev date: 30/01/2009	Technical specification Free-Fall Lifeboat Tanker version	
Doc No: LBF490T-TS115-00	LBF 490 T	Page 1 of 7

1. Technical Data

Dimension:

LOA : 4.90 m
WOA : 2.40 m
HOA : 3.10 m

Boat data

Number of persons : 19
Weight, empty boat : 3055 kg
Weight, davit load : 4480 kg
Certified drop height : 16
Standard propulsion : Propeller
Engine model : BUKH DV29 RME
Speed : 6 knots

2. General Description

Totally enclosed free fall lifeboat tanker version with inboard diesel engine.

3. Regulations

The LBF fully complies with the latest SOLAS requirements and LSA Code.
The LBF will be certified by Bureau Veritas in accordance with the European Council Directive 96/98 EC on Marine Equipment (M.E.D).

Revision no: 01 Rev date: 30/01/2009	Technical specification Free-Fall Lifeboat Tanker version	
Doc No: LBF490T-TS115-00	LBF 490 T	Page 2 of 7

4. Hook system

Freefall operation:

The freefall hook is located at the stern of the boat. The release device is controlled by the helmsman and one set of emergency release system is also provided. The two systems are totally independent of each other. The primary release device is located in the boat cabin next to the helmsman, the secondary one is located aft in cabin.

Hoisting and lowering:

The hoisting and gravity lowering are operated by two double wire ropes attached to three lifting eyes mounted on top of the superstructure.

The hook is made out of galvanized steel (standard), with stainless steel as an option.

5. Building material

The boat is made out of fire retardant glass fibre reinforced polyester material (GRP). Main parts are laminated in independent moulds. To assure buoyancy and strength, foam is injected into certain areas between the inner liner and the hull. To secure hull strength, the hull has longitude bulkheads and transverse bulkheads.

Extra strengthening is built in to bow area to absorb the forces from water masses during diving.

The boat is made with anti-skid on all walking surfaces, inside and outside.

A fender made out of synthetic rubber is mounted on port and starboard side. The fender is connected to the hull with stainless steel screws.

External steel parts are of 316 L quality, inside 304 steel quality is used as standard.

Revision no: 01 Rev date: 30/01/2009	Technical specification Free-Fall Lifeboat Tanker version	
Doc No: LBF490T-TS115-00	LBF 490 T	Page 3 of 7

6. Engine, fuel and steering

Engine:

As standard the LBF 490 T is delivered with BUKH DV29 RME, built according to the requirements of the 1996 amendments to the International Convention for SOLAS 1974 and LSA Code.

- Maker : BUKH
- Model : DV29 RME
- Type : Turbocharged, 4 stroke, 2 cylinders
- Power : 29 hp (21.3 kW)
- Fuel quality : BS 2869 Class A
- Fuel consumption : 7.8 L/H
- Fuel capacity : 180 ltr
- Starting method : Electric starting/ emergency manual starting
- Alternator : 14 V, 50 Amp, 700 W
- Starter : 12 V, 1.36 hp (1.0 kW)
- Spare parts : One set
- Transmission : Disengageable shaft coupling
- Instrument panel :
 - Electric start/stop
 - Power indicator
 - High cooling temperature alarm
 - Low oil pressure alarm
- Closed fresh water keel cooling system with anti-freeze liquid.
- The engine is supplied with two independent starting batteries.
- The engine is easily accessible through a removable inspection cover, made out of fire-retardant and heat-insulating material.
- The engine is installed with a silencer and exhaust pipe which is made out of stainless steel and is wrapped with heat-insulating material.
- The speed of the engine and the control of ahead and astern are all controlled through a cable by the helmsman from the helmsman's position.

Revision no: 01 Rev date: 30/01/2009	Technical specification Free-Fall Lifeboat Tanker version	
Doc No: LBF490T-TS115-00	LBF 490 T	Page 4 of 7

Fuel:

The fuel oil tank is made out of stainless or galvanized steel. The fuel tank capacity will be sufficient to run the fully loaded lifeboat at 6 knots for a period of not less than 24 hours. The tank is also fitted with an exhaust outlet led to the outside of boat.

Shaft and propeller:

The shaft is made out of stainless steel, the supports at the two ends and its couplings are made out of bronze.

- The propeller is of nickel aluminium bronze and is protected by a GRP duct.
- The propelling system and its active parts are all protected.

Steering system:

The steering is achieved by turning a duct rudder that surrounds the propeller. The duct is made out of GRP and also protects the propeller.

The steering rod and its supports are made out of stainless steel.

The duct rudder is operated through a flexible cable by a wheel from the helmsman's position.

In case of failure of the steering flexible cable, the rudder may be directly controlled by a emergency tiller, which is made out of stainless steel and are stowed close to the steering rod.

7. Electrical Equipment

The following electrical equipment is installed in the LBF:

- Two independent batteries of free maintenance type with capacity 90 AH. The batteries are stowed in a GRP container with an ventilation pipe led to the outside.
- Battery control switch
- LADAC 42V type charger connected with the Ladix cable system to the external power supply. Contacts are of quick release type.
- Canopy light

Revision no: 01 Rev date: 30/01/2009	Technical specification Free-Fall Lifeboat Tanker version	
Doc No: LBF490T-TS115-00	LBF 490 T	Page 5 of 7

- Handheld search light
- Position indicating light
- Compass
- Switch panel with integrated fuses

The electric equipment in the LBT is built to IP 56 standard.

8. Fire protection

A water spray system is installed for fire protection. The spray system consists of an engine driven pump which takes sea water from an intake location under the boat ensuring that no flammable liquid is drawn into the system. The spray system provides water over the entire surface of the boat (1300L/min).

9. Air system and ventilation

The compressed air system installed has a sufficient capacity to provide air for the maximum number of persons and engine combustion for a minimum of 10 minutes. It also establishes an overpressure inside the boat to prevent ingress of toxic fumes or gas. Provisions have been made to recharge the air cylinders from the ship's compressed air system.

A pressure relief valve is mounted on the aft bulkhead's port side. The valve prevents the cabin from becoming dangerously over-pressured when the emergency air system is in operation. Natural ventilation is achieved via an automatic valve located on the stern embarkation door. The valve also prevents the cabin from becoming dangerously under-pressured while the engine is running.

Revision no: 01 Rev date: 30/01/2009	Technical specification Free-Fall Lifeboat Tanker version	
Doc No: LBF490T-TS115-00	LBF 490 T	Page 6 of 7

10. Equipment

- Painter hook operated from inside lifeboat
- Skates (synthetic rubber type)
- Fender(synthetic rubber type)
- Buoyant lifeline around the gunwale
- Bilge pump
- Drain plug
- Ventilator (manually closing when capsizing)
- Fore hatch (600x600 mm)
- Aft door (1200x900 mm)
- Side embarkation hatch (1200x900 mm)
- Top hatch (600x600 mm)
- Water spray system
 - Water spray pump operated by engine V-belt
 - Stainless steel type sprinkler system
- Air supply system:
 - Compressed air cylinder 19.6 Mpa (200kgf/cm²) 45 L
 - High pressure hoses
 - High pressure stainless steel connections
 - High pressure valves
- SOLAS equipment according LSA code

11. Colour

External hull/canopy: Gel coat resin of international orange colour RAL 2009
Internal hull/canopy: Painted in light green colour RAL 7035

Revision no: 01 Rev date: 30/01/2009	Technical specification Free-Fall Lifeboat Tanker version	
Doc No: LBF490T-TS115-00	LBF 490 T	Page 7 of 7

12. Identification

- The identification plate is fitted next to the helmsman's position. Following content are described on the identification plate: Type of boat, inspection mark, serial number, main dimensions, number of persons, fully loaded weight, date of completion, name of manufacturer.
- The ship's name, port of registry and number of persons are marked on port and starboard bow.
- Call sign and boat number are marked on top of enclosure.
- The retro-reflective tapes are fitted on top, on the sides and on the stern of enclosure.
- Symbols of life-saving appliances are provided in the vicinity of the helmsman's position and nearby each storage compartment.

13. Documentation

Following final documents are submitted after delivery:

- Product specifications
- General arrangement drawings
- User instruction manuals
- Instructions for on-board maintenance of lifeboat

14. Guarantee

NOREQ AS liability for defects is limited to defects which appear within a period of 12 months from the buyer's further delivery of the equipment to the buyer's customer as an integrated part of the ship, or within a maximum of 18 months from delivery to the buyer, whichever comes first.

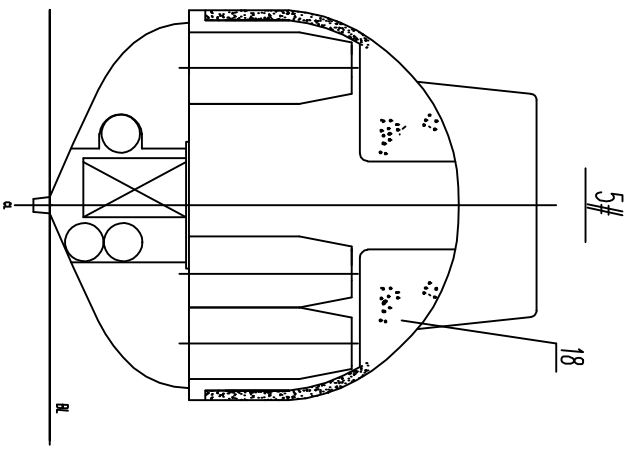
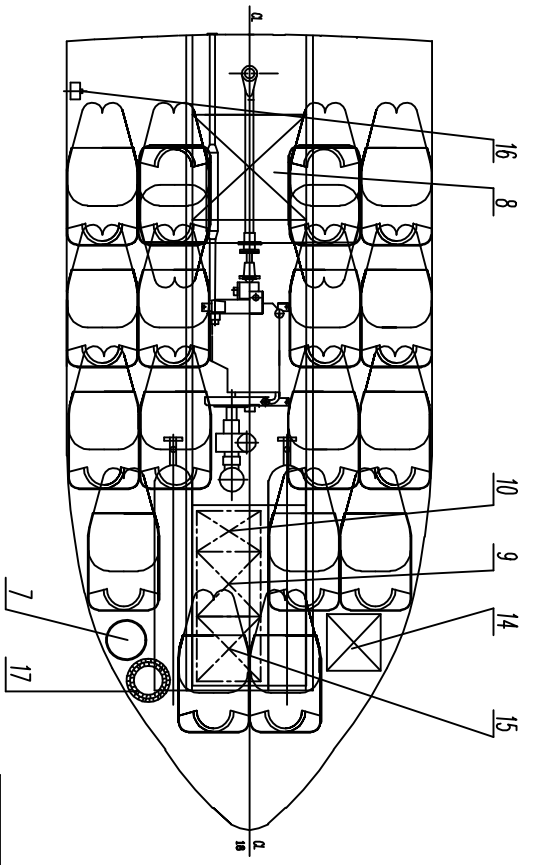
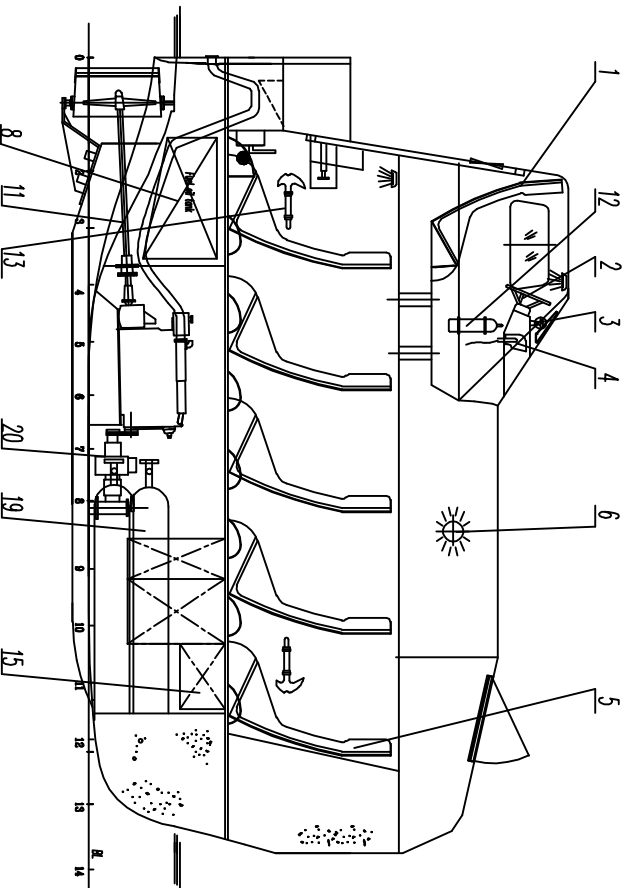

20	Sprinkle water system	1	Assemble	
19	High pressure air cylinder	3	Product	
18	Air case arrangement plan	1	F.R.P	
17	Painter	1	Product	
16	Manual pump	1	Product	
15	Battery box	1	Product	
14	Storage box	1	F.R.P	
13	Safety hatchet	2	Product	
12	Portable extinguisher	1	Product	
11	Engine starting dropeller	1	Assemble	
10	Food case	1	F.R.P	
9	Fresh case	1	F.R.P	
8	Fuel oil tank	1	A3	
7	Dirty bucket	1	Product	
6	Canopy light	3	Product	
5	Seat	18	F.R.P	
4	Search light	1	Product	
3	Compass	1	Product	
2	Steering gear device	1	Assemble	
1	Pilot chair	1	F.R.P	
Item	Description	Qty	Material	Remark

General Arrangement Drawing

Design: YJF
 Check: PDY
 Approval: DYF
 Date: 15.12.2006

NOREQ-LBF 490 T



Dwg No. NS049B-100-02 Page B-2