

Revision no: 01 Rev date: 31/01/2009	Technical specification Totally Enclosed Lifeboat Cargo version	
Doc No: LBT935C-TS110-00	LBT 935 C	Page 1 of 6

1. Technical Data

Dimension:

LOA	: 9.35 m
WOA	: 3.60 m
HOA	: 3.25 m

Boat data

Number of persons	: 102
Weight, empty boat	: 5100 kg
Weight, davit load	: 12750 kg
Hook distance	: 8.95 m*
Standard propulsion	: Propeller
Engine model	: BUKH DV29 RME
Speed	: 6 knots

* Standard hook distance, may be modified on request.

2. General Description

Totally Enclosed Lifeboat (Cargo Version) with inboard diesel engine.

3. Regulations

The LBT fully complies with the latest SOLAS requirements and LSA Code. The LBT will be certified by Bureau Veritas in accordance with the European Council Directive 96/98 EC on Marine Equipment (M.E.D).

Revision no: 01 Rev date: 31/01/2009	Technical specification Totally Enclosed Lifeboat Cargo version	
Doc No: LBT935C-TS110-00	LBT 935 C	Page 2 of 6

4. Lifting Arrangement

LBT is equipped with NOREQ-HOOK 8.8 T fore and aft. The hooks will be released simultaneously through the flexible cables controlled from the helmsman's position. Hooks can be released either, when the boat is waterborne or when there is no load on the hooks.

In emergency cases the hooks can be released during load by breaking a safety glass and remove the safety pin (as per SOLAS and LSA Code 4.4.7.6)

The hooks are made out of galvanized steel (standard), with stainless steel as an option.

5. Building material

The boat is made out of fire retardant glass fibre reinforced polyester material (GRP). Main parts are laminated in independent moulds. To assure buoyancy and strength, foam is injected into certain areas between the inner liner and the hull. To secure hull strength, the hull has longitude bulkheads and transverse bulkheads.

The boat is made with anti-skid on all walking surfaces, inside and outside.

A fender made out of synthetic rubber is surrounding the hull. The fender is connected to the hull with stainless steel screws.

External steel parts are of 316 L quality, inside 304 steel quality is used as standard.

Revision no: 01 Rev date: 31/01/2009	Technical specification Totally Enclosed Lifeboat Cargo version	
Doc No: LBT935C-TS110-00	LBT 935 C	Page 3 of 6

6. Engine, fuel and steering

Engine:

As standard the LBT 935 C is delivered with BUKH DV29 RME, built according to the requirements of the 1996 amendments to the International Convention for SOLAS 1974 and LSA Code.

- Maker : BUKH
- Model : DV29 RME
- Type : Turbocharged, 4 stroke, 2 cylinders
- Power : 29 hp (21.3 kW)
- Fuel quality : BS 2869 Class A
- Fuel consumption : 7.8 L/H
- Fuel capacity : 180 ltr
- Starting method : Electric starting/ emergency manual starting
- Alternator : 14 V, 50 Amp, 700 W
- Starter : 12 V, 1.36 hp (1.0 kW)
- Spare parts : One set
- Transmission : Disengageable shaft coupling
- Instrument panel :
 - Electric start/stop
 - Power indicator
 - High cooling temperature alarm
 - Low oil pressure alarm
- Closed fresh water keel cooling system with anti-freeze liquid.
- The engine is supplied with two independent starting batteries.
- The engine is easily accessible through a removable inspection cover, made out of fire-retardant and heat-insulating material.
- The engine is installed with a silencer and exhaust pipe which is made out of stainless steel and is wrapped with heat-insulating material.
- The speed of the engine and the control of ahead and astern are all controlled through a cable by the helmsman from the helmsman's position.

Revision no: 01 Rev date: 31/01/2009	Technical specification Totally Enclosed Lifeboat Cargo version	
Doc No: LBT935C-TS110-00	LBT 935 C	Page 4 of 6

Fuel:

The fuel oil tank is made out of stainless or galvanized steel. The fuel tank capacity will be sufficient to run the fully loaded lifeboat at 6 knots for a period of not less than 24 hours. The tank is also fitted with an exhaust outlet led to the outside of boat.

Shaft and propeller:

The shaft is made out of stainless steel, the supports at the two ends and its couplings are made out of bronze.

- The propeller is of nickel aluminium bronze and is protected by a GRP duct.
- The propelling system and its active parts are all protected.

Steering system:

The steering is achieved by turning a duct rudder that surrounds the propeller. The duct is made out of GRP and also protects the propeller.

The steering rod and its supports are made out of stainless steel.

The duct rudder is operated through a flexible cable by a wheel from the helmsman's position.

In case of failure of the steering flexible cable, the rudder may be directly controlled by a emergency tiller, which is made out of stainless steel and are stowed close to the steering rod.

7. Electrical Equipment

The following electrical equipment is installed in the LBT:

- Two independent batteries of free maintenance type with capacity 90 AH. The batteries are stowed in a GRP container with an ventilation pipe led to the outside.
- Battery control switch
- LADAC 42V type charger connected with the Ladix cable system to the external power supply. Contacts are of quick release type.

Revision no: 01 Rev date: 31/01/2009	Technical specification Totally Enclosed Lifeboat Cargo version	
Doc No: LBT935C-TS110-00	LBT 935 C	Page 5 of 6

- Canopy light
- Handheld search light
- Position indicating light
- Compass
- Switch panel with integrated fuses

The electric equipment in the LBT is built to IP 56 standard.

8. Equipment

- Painter hook operated from inside lifeboat
- Skates (synthetic rubber type)
- Fender(synthetic rubber type)
- Buoyant lifeline around the gunwale
- Bilge pump
- Drain plug
- Ventilator (manually closing when capsizing)
- Fore hatch (600x600 mm)
- Aft door (1200x900 mm)
- Side embarkation hatch (1200x900 mm)
- Top hatch (600x600 mm)
- SOLAS equipment according LSA code

9. Colour

External hull/canopy: Gel coat resin of international orange colour RAL 2009
Internal hull/canopy: Painted in light green colour RAL 7035

Revision no: 01 Rev date: 31/01/2009	Technical specification Totally Enclosed Lifeboat Cargo version	
Doc No: LBT935C-TS110-00	LBT 935 C	Page 6 of 6

10. Identification

- The identification plate is fitted next to the helmsman's position. Following content are described on the identification plate: Type of boat, inspection mark, serial number, main dimensions, number of persons, fully loaded weight, date of completion, name of manufacturer.
- The ship's name, port of registry and number of persons are marked on port and starboard bow.
- Call sign and boat number are marked on top of enclosure.
- The retro-reflective tapes are fitted on top, on the sides and on the stern of enclosure.
- Symbols of life-saving appliances are provided in the vicinity of the helmsman's position and nearby each storage compartment.

11. Documentation

Following final documents are submitted after delivery:

- Product specifications
- General arrangement drawings
- Instruction manuals
- Instructions for on-board maintenance of lifeboat

12. Guarantee

NOREQ AS' liability for defects is limited to defects which appear within a period of 12 months from the buyer's further delivery of the equipment to the buyer's customer as an integrated part of the ship, or within a maximum of 18 months from delivery to the buyer, whichever comes first.

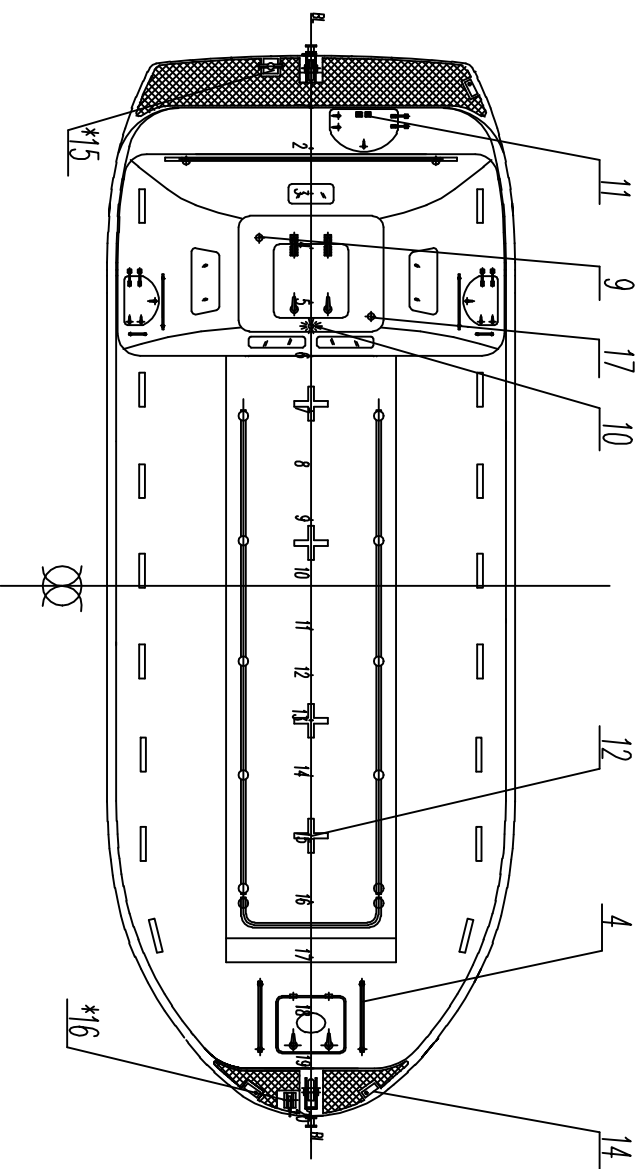
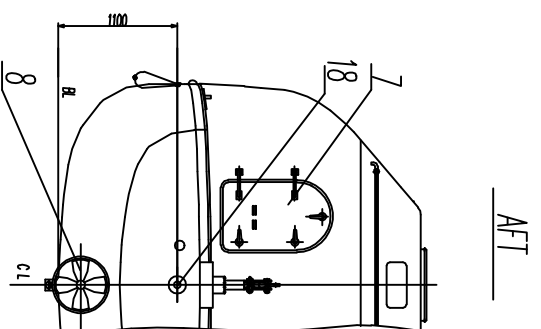
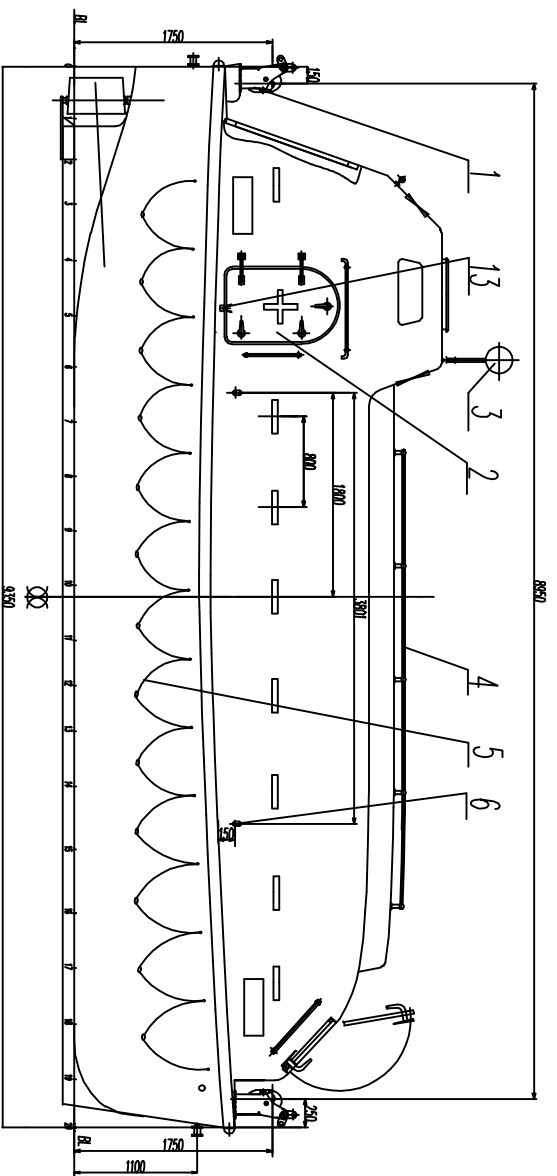

NOTE: * IT IS ONLY PORT SIDE BOAT STARBOARD IS

SYMMETRIC TO PORT SIDE BOAT.

18	Guide wheel	2	Gal steel	
17	Seat of radar reflector	1	Stainless steel	
16	Painter device	1	Assemble	
15	Bit	1	Stainless steel	
14	Chock	3	Stainless steel	
13	Oar hole & seat	2	F.R.P	
12	Retro-reflector band	50	Plastic	
11	Ventilator	1	Assemble	
10	Position light	1	Product	
9	Remote control line hole	2	Assemble	
8	Pivot duct & steering arrangement	1	Assemble	
7	Aft door	1	Assemble	
6	Stale eye-plate	4	Stainless steel	
5	Lifeline appliance	1	Assemble	
4	Hand Rail	4	Stainless Steel	
3	Radar Reflector	1	Product	
2	Side door	2	Assemble	
1	Hook device arrangement	1	Assemble	

General Arrangement Drawing

Design: Yang Jiping
 Check: Peng Dexing
 Approve: Ding Yufei
 Date: 06/2007

Totally Enclosed Lifeboat
 NOREQ-LBT 935 C



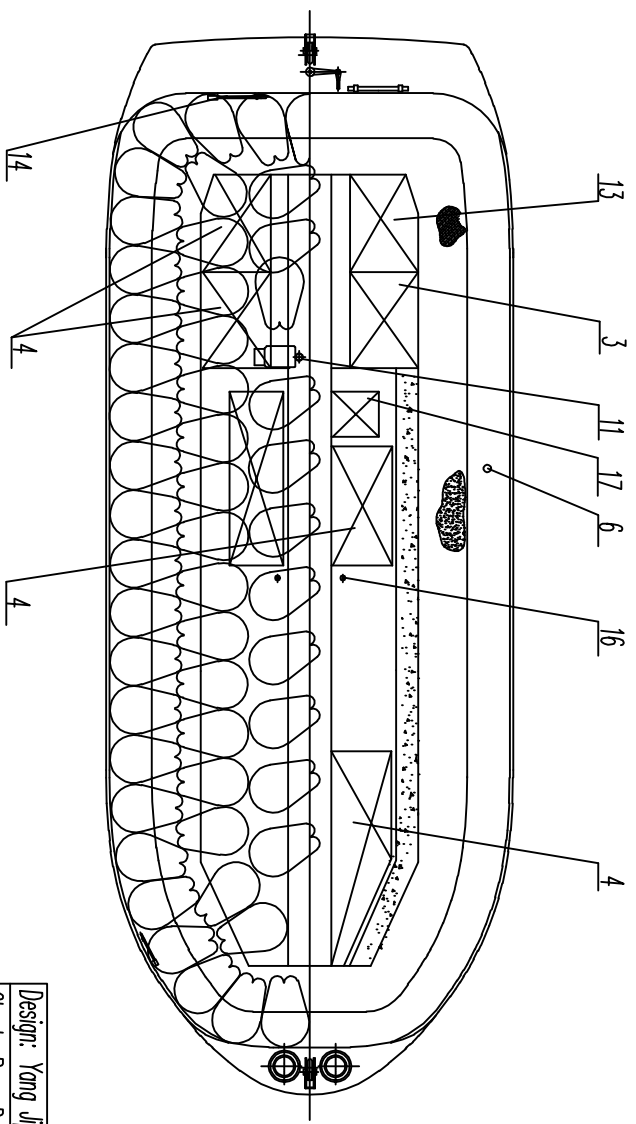
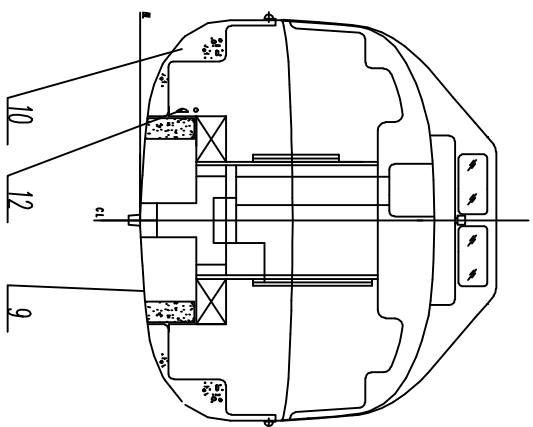
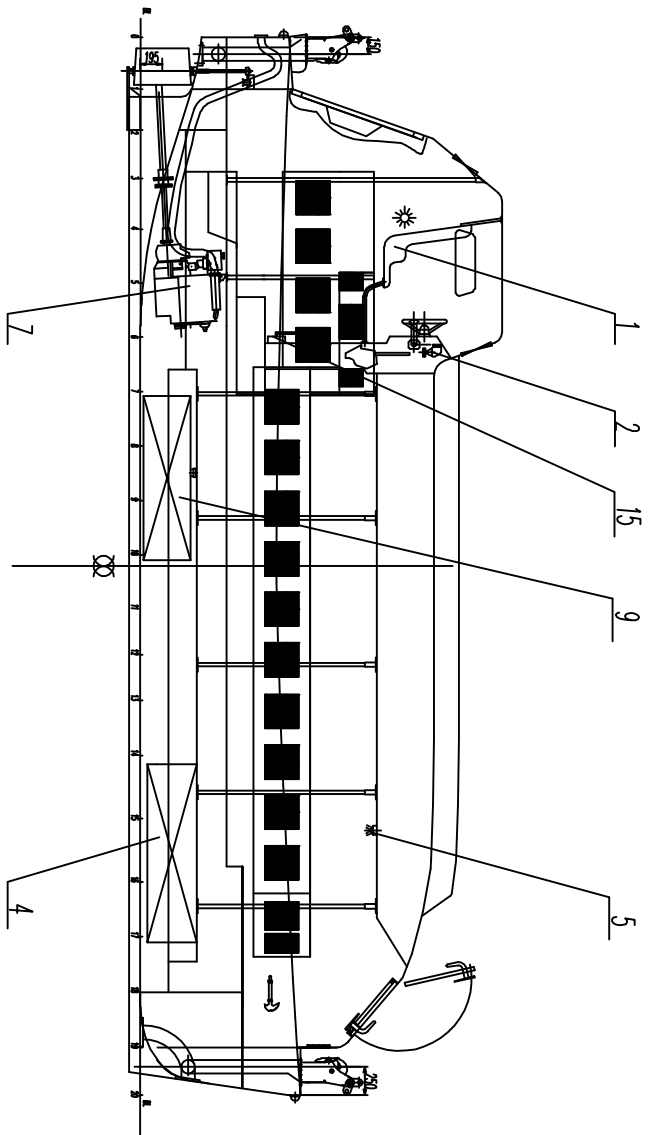

17	Battery box	1	F.R.P	
16	Drain plug	2	Assemble	
15	Manual pump	1	Assemble	
14	Safety hatchel	2	Product	
13	Goods box	1	F.R.P.	
12	Oar & punt-pole	2	Assemble	
11	Portable extinguisher	1	Product	
10	Air case arrangement plan	1	F. R. Pdf form	
9	Structure plan	1	Assemble	
8	Fuel oil tank	1	Gal steel	
7	Engine shafting & propeller	1	Assemble	
6	Safety seat device	102	Assemble	
5	Tent light	2	Product	
4	Fresh water case	5	F.R.P	
3	Food case	1	F.R.P	
2	Search light	1	Product	
1	Pilot chair	1	Assemble	
Item	Description	Qty	Material	Remark

General Arrangement Drawing

Design: Yang Jiping
 Check: Peng Dexing
 Approve: Ding Yufei
 Date: 06/2007

Totally Enclosed Lifeboat
 NOREQ-LBT 935 C



Dwg No. JCS2011A-100-03
 Page B-2

