

Revision no: 01 Rev date: 30/01/2009	Technical specification Rigid Rescue Boat	
Doc No: RRB525-TS138-00	RRB 525	Page 1 of 4

1. Technical Data

Dimension:

Length : 5.25 m
Width : 2.00 m
Height : 0.90 m

Boat data

Number of persons : 6
Weight, empty boat : 740 kg
Weight, davit load : 1220 kg
Standard propulsion : Propeller
Model : BUKH DV24 RME
Speed : 6 knots
Towing force : 135 kg
Lifting arrangement : Lifting sling of SWL 1500 kg

2. Regulations

The FRB fully complies with the latest SOLAS requirements and LSA Code. The FRB will be certified by Bureau Veritas in accordance with the European Council Directive 96/98 EC on Marine Equipment (M. E. D).

3. Lifting Arrangement

Single point lifting arrangement with approved on/off load release hook. Standard supply NOREQ-HOOK 3 T. It is connected through a stainless steel frame to the hull bulkheads.

Revision no: 01 Rev date: 30/01/2009	Technical specification Rigid Rescue Boat	
Doc No: RRB525-TS138-00	RRB 525	Page 2 of 4

4. Deck and Hull

The boat is made out of fire retardant glass fibre reinforced polyester material (GRP). Main parts are laminated in independent moulds. To assure buoyancy and strength, foam is injected into certain areas between the inner liner and the hull. There is also bulkheads built up with the keel to assure hull strength. A synthetic fender reinforced with stainless steel bar is fitted around the boat hull and protecting the boat against impact. All steel fittings are of stainless steel quality 316 L.

The boat is designed with the capability of being righted by not more than two persons with two handrails at each side.

The boat is equipped with an anti-skid surface deck.

5. Engine and accessories

RRB 525 is equipped with an inboard 24hp diesel engine, which satisfies the requirements of 1996 amendments to SOLAS 1974 and LSA Code. The engine is also approved by Classification Society.

Technical data:

Model : BUCK DV24 RME 4 stroke
Power : 17.70 kW
Fuel : Diesel
Tank : 50 ltr in total
Starting method : Electrical/Manual operating

Particulars:

- Propeller protection guard.
- Fuel sufficient for 4 hours operation at speed over 6 knots.

Revision no: 01 Rev date: 30/01/2009	Technical specification Rigid Rescue Boat	
Doc No: RRB525-TS138-00	RRB 525	Page 3 of 4

6. Fittings and Console

The main operation of the boat is carried out from the manual operated handle of the engine fitted at stern.

The following equipment is fitted on the console:

- Hydraulic steering gear
- Remote control for engine on right hand side
- Hand held search light
- Compass

7. Electrical equipment

Standard supply is a 42V LADAC battery charger, charging the two independent 12V batteries. The electric system is controlled by a battery switch, together with a switch panel for navigation lights (red, green and white), light in compass and search light.

Electric equipment is according to IP 56 standard.

8. Self righting capability

At the stern a buoyancy foam filled arrangement is mounted. This will make the boat capable of returning to upright position after capsizing.

During capsizing the engine will automatically shut off.

9. Equipment

A painter release hook is fitted at the bow, buoyant lifelines and grips are fitted on both sides. A manually operated bilge pump is installed, and all the other equipments required by LSA are provided. Tools and spares for the engine are also supplied as per regulation.

Revision no: 01 Rev date: 30/01/2009	Technical specification Rigid Rescue Boat	NOREQ[®]
Doc No: RRB525-TS138-00	RRB 525	Page 4 of 4

10. Documentation

Following final documents are submitted after delivery:

- Product specifications
- General arrangement drawings
- User instruction manuals
- Instructions for on-board maintenance of lifeboat

11. Guarantee

NOREQ AS' liability for defects is limited to defects which appear within a period of 12 months from the buyer's further delivery of the equipment to the buyer's customer as an integrated part of the ship, or within a maximum of 18 months from delivery to the buyer, whichever comes first.

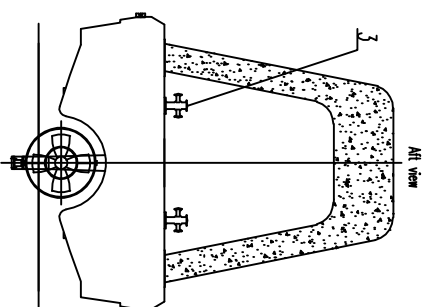
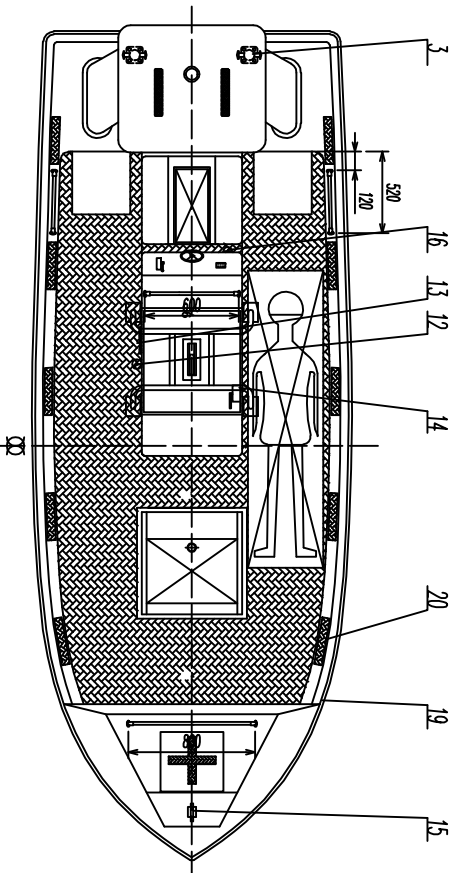
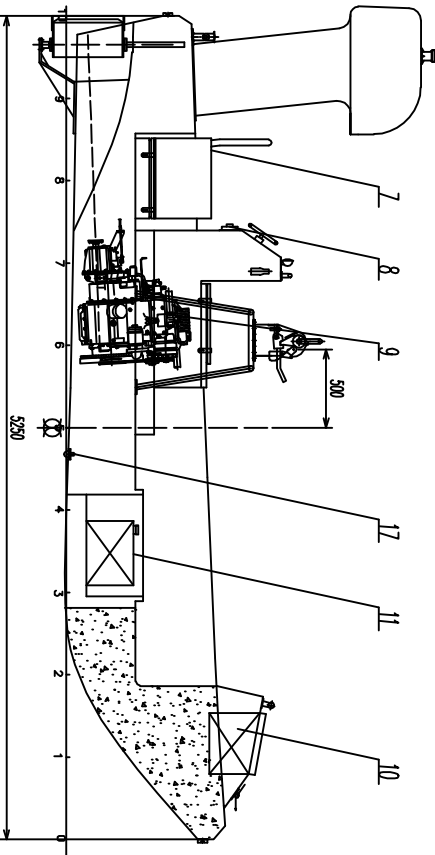
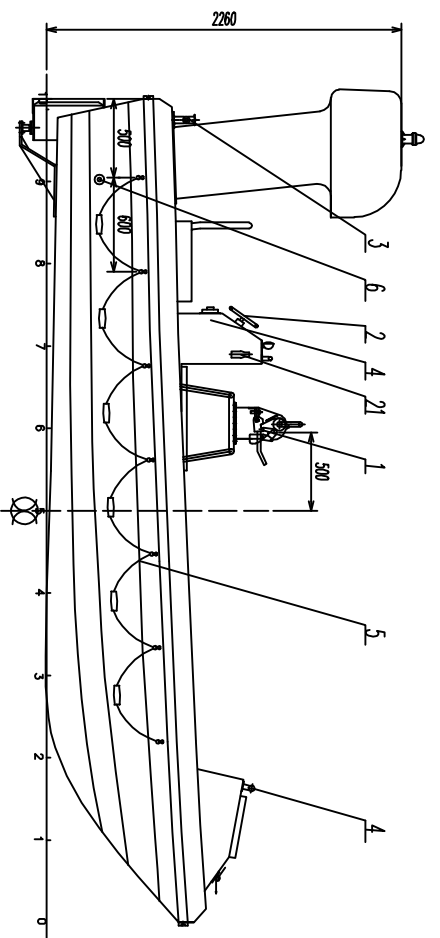

21	Charger socket	1	Plastic	
20	Reflector Tape	14	Plastic	
19	Fender	1	Rubber	
17	Drain plug	1	Brass	
16	Search light	1	FRP	
15	Painter device	1	Stainless steel	
14	Hande pump	1	Assemble	
13	Hatchet	1	Product	
12	Extinguisher	1	Product	
11	Fuel oil tank	1	Product	
10	Battery bus	1	FRP	
9	Diesel engine	1	Product	
8	Switch	1	Product	
7	Plat seal	1	FRP	
6	Stainer	2	Rubber	
5	Lifeline Device	1	Assemble	
4	Handrail	3	Stainless Steel	
3	Bit	2	SIS	
2	Control Device	1	Assemble	
1	Hook Device	1	Al	
Item	Description	Qty	Material	Remark

General Arrangement Plan

Design: Yang Jijing
 Check: Peng Dexing
 Approve: Ding Yufei
 Date: 20/03/2007

NOREQ-RRB 525

Dwg No. JCS525-100-02
 Page: B-1

